



## Addressing Corrosion in Offshore Pneumatic Tubing

# T-SEP™

## Install Instructions

- 1) Remove tape backing on “Bottom Tube Alignment Section”.

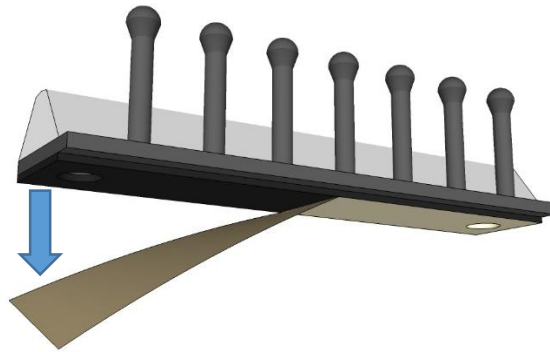

- 2) Place “Bottom Tube Alignment Section” in tray.  
*Note: Once alignment section is taped in place, movement is difficult.*

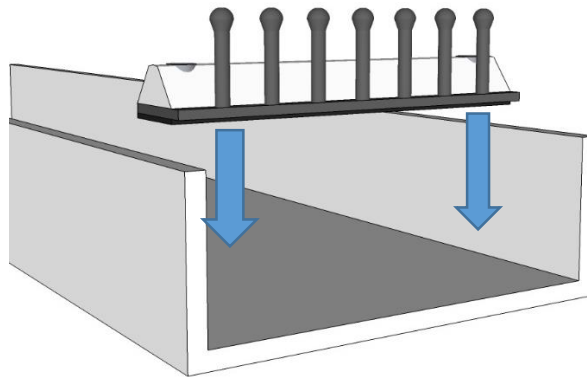

- 3) Once hardware holes are drilled in tray (using Tube Alignment Section as a guide), tubes can be snapped into place.

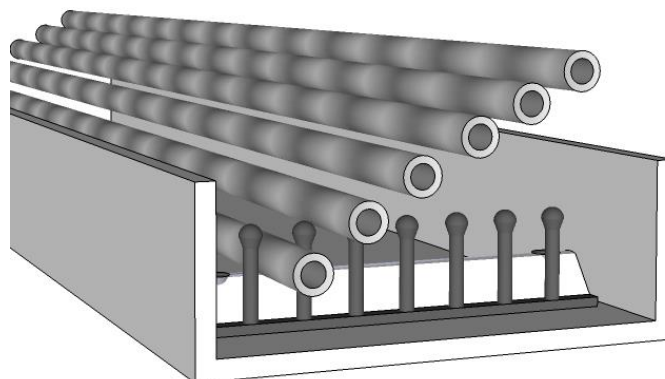

Turn Over

- 4) Once tubes are in place, the “Top Retainer” can be fastened into place with hardware

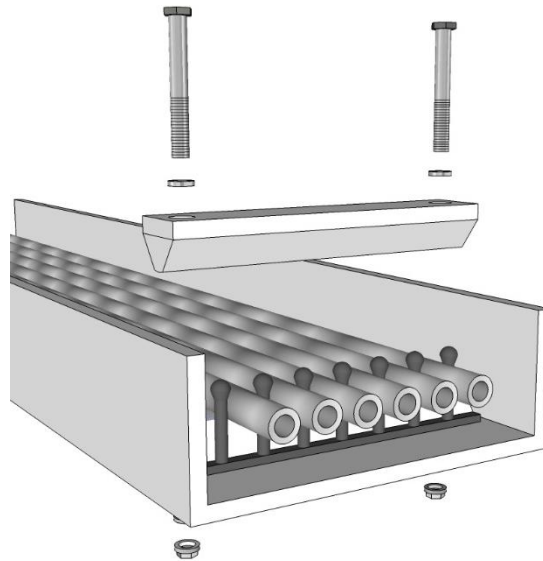

- 5) Completed install should resemble an hour glass. Always tighten by hand and avoid using torque wrench. Over-tightening can result in incorrect retainer alignment. Adjustments can be made through loosening hardware to attain proper configuration.

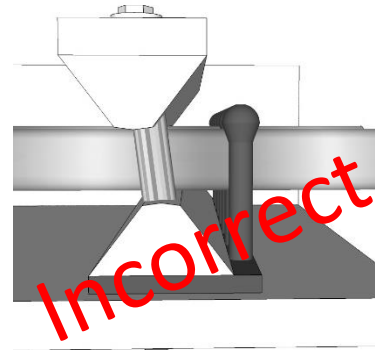
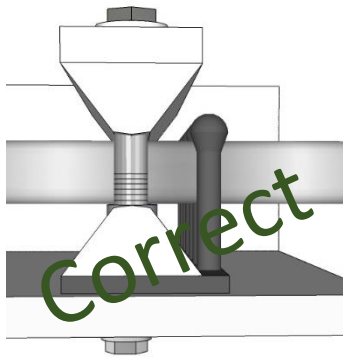

- 6) Proper tube alignment is critical for utilizing entire T-SEP capacity. Misalignment can result in spacer tines impeding on adjacent tube run access area.

